

MACHINING TRESPA

CONTENTS

1. Machining Trespa.....	2
1.1 Introduction.....	2
1.2 Safety	2
2. Sawing.....	4
2.1 Introduction.....	4
2.2 Tools.....	4
2.2.1 Hand tools	4
2.2.2 Fixed machines	5
2.4 Possible problems when sawing.....	11
3. Finishing (of edges).....	12
3.1 Introduction.....	12
3.2 Tools.....	12
3.2.1 Hand tools	12
3.2.2 Fixed machines	13
4. Drilling	15
4.1 Introduction.....	15
4.2 Tools.....	15
4.3 General guidelines	16
4.4 Possible problems when drilling.....	17
5. Punching	18
6. Suppliers	18

1. Machining Trespa

1.1 Introduction

The construction of Trespa panels guarantees a homogeneous composition of the material, so that it is possible to machine both the sides and the surface. The machined areas do not require any protective or covering treatment.

The sides of panels may be treated with a silicon-free furniture oil to make them attractive for interior applications. If desired, the sides may be varnished using a number of 2-component acrylic, polyurethane or epoxy varnishing systems.

Trespa panels may be machined using carpentry tools. Machining Trespa panels is comparable to machining hardwood. The hardness of Trespa places higher demands on the tools than when machining materials composed of softwood.

Hard metal tools are recommended for constructing larger series. Diamond-studded tools are recommended for very large series and when using advanced machines (multi-purpose machines). This material produces a very good finish and has a very long tool life.

Trespa panels can be machined without any problems as long as the following guidelines are taken into consideration:

- Use machines with stationary tools and moving worktops.
- Have the visible surface facing upwards when sawing, routing, and drilling, etc.
- Prevent sliding the panels as much as possible.
- When the visible side must be slid over the machine's worktop whilst machining, it is recommended to place a protective panel, for example of hardwood, on the worktop.
- Lift the panels and avoid sliding them as much as possible, also during transport and assembly.
- Use insert templates covered with rubber mats to prevent the panels from sliding if the machine does not have a moving worktop and/or if you are machining double-sided panels.

1.2 Safety

Dangers are inherent with the use of machinery. In all cases, following the recommendations of the Labour Inspectorate as much as possible can reduce the dangers. These recommendations can be found in the Arbo (=Work Conditions) information sheets (AI-sheets), the successor to the P-sheets. These sheets contain information on how employers and employees can turn the Health and Safety Law (Dutch Arbeidsomstandighedenwet) into practice. They are provided under the auspices of the Dutch ministry of Social Services and Employment and are used, for example, by the Labour Inspectorate.

The dangers when working with carpentry machines can be divided into a number of categories:

1. Coming into contact with rotating cutting tools:
 - Always use the protective aids available correctly.
 - Make sure the power to the machine is turned off when carrying out maintenance work on the machine.
 - Take extra care when setting cutting tools.
 - Make sure the panel is securely held in place.
 - Always remain still when the material is being fed into the machine. Do not walk with the material.
2. Backlash from the panel or waste material:
 - Make sure the blade of the sawing machine is high enough above the sawing bench so that the material does not immediately come into contact with the teeth which move in the direction of the person sawing whilst the material is being fed into the machine.

- Make sure the material cannot get stuck between the machine frame and the tool.
- 3. Rotating cutting tools braking off or coming loose:
 - Make sure the tool is well ground.
 - Use the right tool and make sure it is in good condition.
 - Select the correct relation between the rotational speed and the feed.
 - Make sure the machine is well balanced.
 - Make sure the tools are well secured.
 - Always wear protective goggles.
- 4. Noise level:
 - Setting the machine correctly can prevent too much noise.
 - Always wear ear protection.
- 5. The production of dust:
 - Make sure the dust extraction unit functions correctly.

2. Sawing

2.1 Introduction

Trespa panels can be sawn without any problem if the correct tool is used and the correct settings are chosen.

The choice of tool and the accompanying setting depend on a number of factors:

- Total distance to be machined.
- Thickness of the panel.
- Required finishing quality.

The distance to be machined determines whether hand tools or fixed tools are to be used.

Hand tools are mainly used for single panels requiring smaller cuts. Fixed machines are used for larger series and larger cuts.

The thickness of the panel to be machined and the required finishing quality place demands on the tools to be used and the machine setting.

The description below gives a number of recommendations with regard to the choice and use of sawing tools. The final result, however, always depends on the will of the person carrying out the sawing to produce a good product.

2.2 Tools

2.2.1 Hand tools

Hand tools are often used at the construction site and/or for the manufacture of small series.

■ Handsaw

A handsaw may only be used to saw straight lines. The best results are achieved using a lightly set, fine-toothed handsaw. Good results are achieved using a Sandvik saw with 7 teeth per thumb. If necessary, a normal metal saw can also be used to saw Trespa panels.

■ Portable circular saw

A portable circular saw is mainly used for making rough cuts. It can also be used at the construction site to shorten panels and to cut them to size. A guide must be used to make a straight cut. A stable saw plate (thickness > 2 mm) should be used when sawing Trespa panels. Good tool life times are achieved by using hard metal tools with the alternating tooth system.

The setting of a portable circular saw also influences the quality of the cutting edges. Always ensure the correct relation between the rotational speed and the feed, and set the saw plate to the correct height. Table 1 gives guidelines for the cutting speed and feed of the material. The correct rotational speed and feed speed can be determined using formulas 1 and 2.

■ Jigsaw

A jigsaw can be used to cut non-straight lines and recesses. The best results are achieved using a thin, fine-toothed blade, such as blades used for sawing metal. Trespa panels can be sawn using an HSS or HM blade. Hard metal saws have a longer tool life.

The setting for machining metal is used as a guideline for the speed of the jigsaw. Due to the upward sawing movement of the jigsaw, the visible side of the panel should always face the

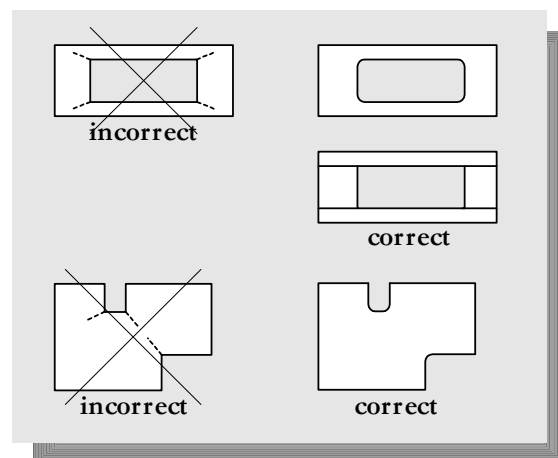

worktop. The inner angles must never be too sharp due to notch fractures (see figure 1). It is recommended to drill out these corners (minimum \varnothing 6 mm).

2.2.2 Fixed machines

Fixed machines are often used in the workshop for larger series.

■ Circular saw

A circular saw is used to saw straight lines. Hard metal tools are recommended.

The type of saw plate, together with the feed speed and the cutting speed, largely determines the quality of the cutting edge. Its dimensions characterize a saw plate, the geometry of the teeth and the shape of the teeth.

The dimensions of a saw plate are given as follows:

\varnothing D x B x d x Z Example: \varnothing 300 x 3.3 x 30 x 96

D = Diameter of the saw plate

B = Width of the cut

d = Diameter of the shaft hole

Z = Number of teeth

The characterizing dimensions of the teeth are described before the different shapes are discussed.

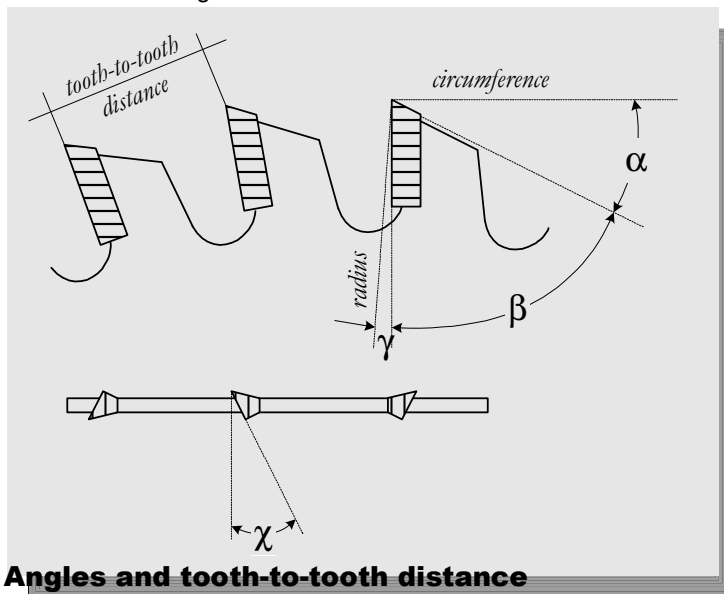

The geometry of the teeth is determined by the following characteristic measurements:

- Tooth-to-tooth distance
- Cutting-edge side rake (γ)
- Key angle (β)
- Clearance angle (α)
- Shaft angle (χ)

The tooth-to-tooth distance depends on the size of the saw plate and the number of teeth. The smaller the tooth-to-tooth distance, the better the quality of the cutting edge, since the saw cuts through the material more evenly.

The angles of the teeth help to determine the quality of the cutting edge. The recommended angles are given

in table 1. This table assumes that a positively ground saw plate is used. These blades have a positive cutting-edge side rake angle.

A very smooth cutting edge is produced when using saw plates with a negative cutting-edge side rake angle. The cutting edge of the panel is then immediately finished, since the special shape of the teeth cuts and planes the material in one go.

A negatively ground saw plate has a shorter tool life than a positively ground saw plate.

TOOTH SHAPES

Possible tooth shapes include:

- Flat tooth
- Alternating tooth
- Duploviet tooth
- Trapezium flat tooth

Flat tooth: the flat tooth is the most simple tooth shape and is for general use. The flat tooth can be ground without any problem. This shape of tooth is less suitable for using with Trespa panels. There is a high risk of splintering when using this shape of tooth.

Alternating tooth: this is the most universal tooth shape for longitudinal cutting and for cutting panels to size. The left-hand half and right-hand half of the cut are cut away alternately. The pointed tooth shape allows the teeth to cut through the panel more easily than the flat tooth. The alternating tooth has a tool life of 1,500 metres.

Duploviet tooth: the hollow shape means that each tooth grips the panel on two sides. The teeth are not used alternately as with the alternating tooth system. The Duploviet tooth has a tool life of 4,000 metres. The disadvantage of this shape of tooth is the high cost of grinding.

Trapezium flat tooth: a smaller flat tooth without facets follows a taller flat tooth with facets. The trapezium tooth is generally 0.2 – 0.3 mm higher. Since the cut is, as it were, cut away in five parts, a saw plate of this type has a tool life of 3,600 metres.

Table 1 gives a number of guidelines for a circular saw:

Plate thickness [mm]	2.8 – 4.8
Diameter [mm]	300 - 450
Number of teeth	45 - 80
Cutting-edge side rake	8° - 12°
Clearance angle	10° - 15°
Cutting speed [m/s]	40 - 60

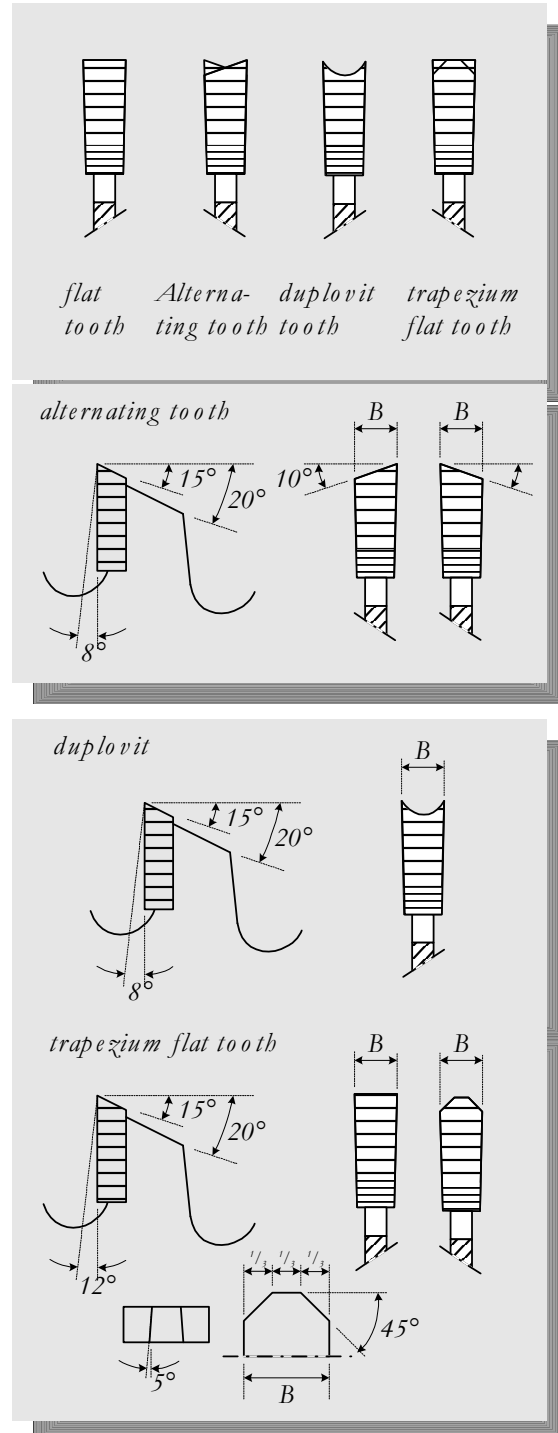

Feed speed [mm/tooth]	0.02 – 0.05
-----------------------	-------------

The rotational speed and the feed for the sawing machine can be determined using the guidelines for the cutting speed and the feed speed.

ROTATIONAL SPEED

The rotational speed of the saw depends on the diameter of the saw plate and the desired cutting speed. The rotational speed is calculated using the following formula.

$$n = \frac{v \times 60}{\pi \times D}$$

n = Rotational speed of the saw plate [r.p.m.]
 v = Cutting speed [m/s]
 D = Saw plate diameter [m]

Example: Saw plate Ø = 300 x 3.3 x 30 x 96. Desired cutting speed of the saw plate: 50 m/s. The rotational speed is then:

$$n = \frac{v \times 60}{\pi \times D} = \frac{50 \times 60}{\pi \times 300} = 3181 \approx 3000 \text{ r.p.m.}$$

FEED

The feed of the material depends on the saw plate's rotational speed and the number of teeth. The feed is calculated using the following formula.

$$S = \frac{s_z \times n \times Z}{1000}$$

S = Feed of material [m/min]
 S_z = Feed per tooth [mm/tooth]
 n = Rotational speed of saw plate [r.p.m.]
 Z = Number of teeth [-]

Example: Saw plate Ø 300 x 3.3 x 30 x 96. Desired material feed: 0.04 mm/tooth. The feed is then:

$$S = \frac{s_z \times n \times Z}{1000} = \frac{0.04 \times 3000 \times 96}{1000} = 11.5 \text{ m/min}$$

The rotational speed and feed can also be determined using the following graphs. Graph 1 is used to determine the rotational speed of the saw plate depending on the desired cutting speed and the saw plate diameter. Graph 2 is used to determine the feed of the material depending on the desired feed per tooth, the number of teeth and the rotational speed of the saw plate.

Graph for determining the cutting speed

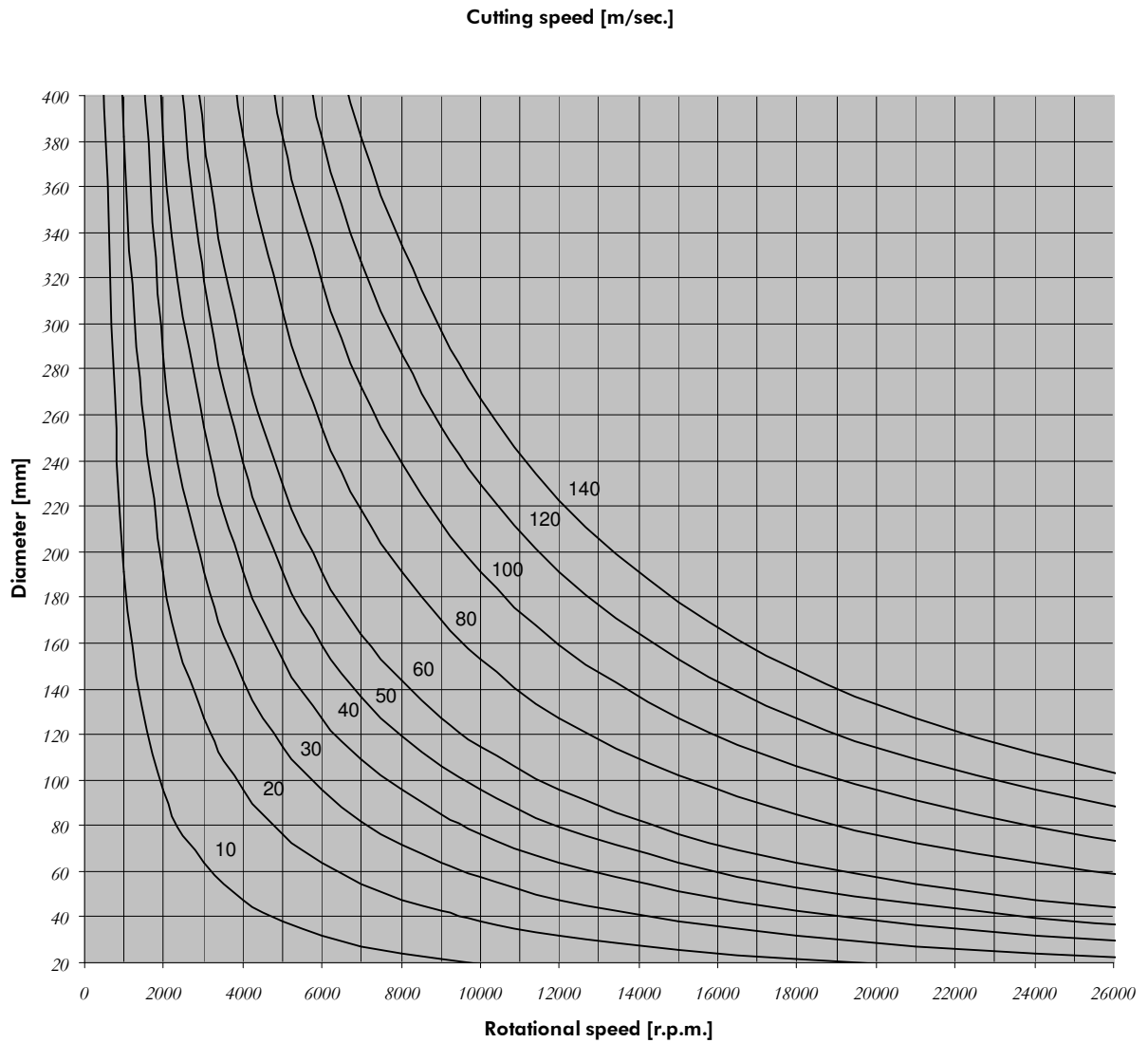

Graphs for determining the feed

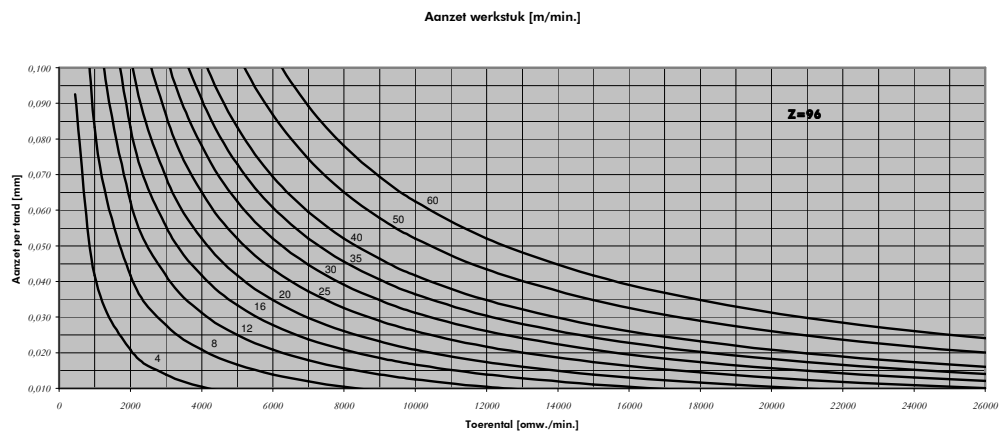
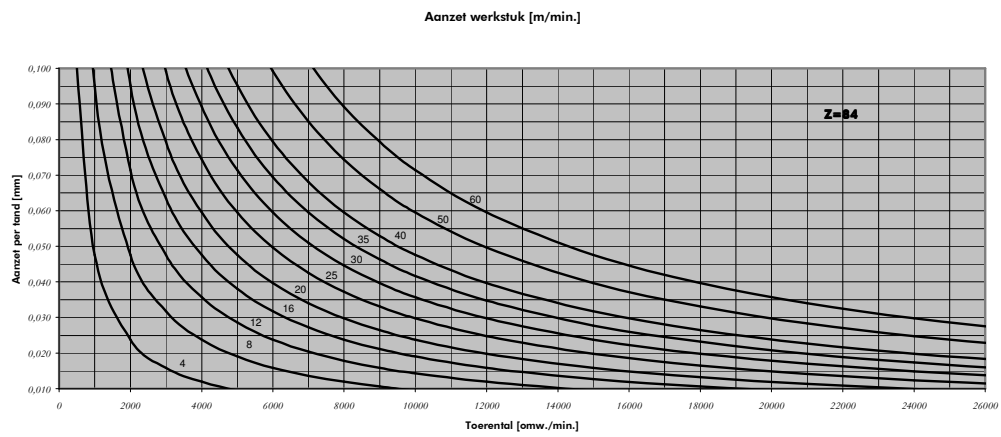
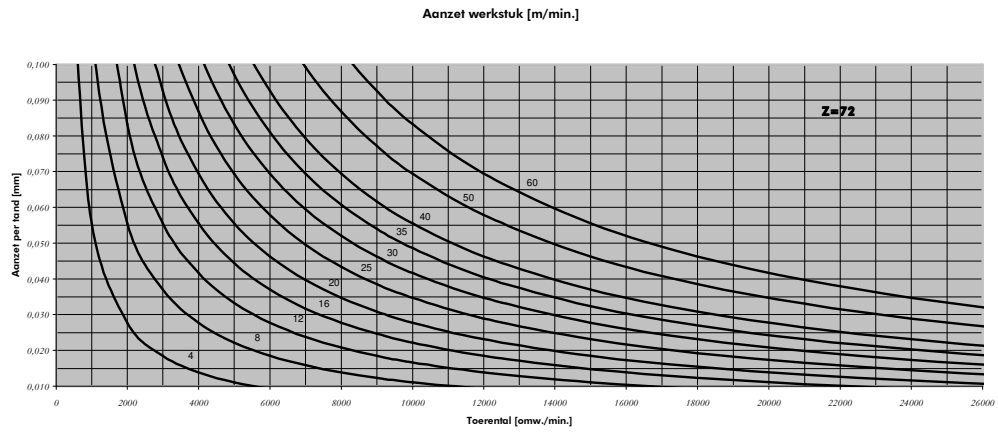

HEIGHT SETTING

The angle with which the saw plate grips into the material also determines the quality of the cutting edge. The entrance angle (and, therefore, also the exit angle) depends of the diameter of the saw plate, the cutting-edge side rake (γ) and the height setting of the saw plate. A larger saw plate has a positive influence over the cutting edge. A large cutting-edge side rake produces a favourable entrance angle and an unfavourable exit angle. The opposite is true for a small cutting-edge side rake.

The same applies for the saw plate's height setting; a large distance between the top of the saw plate and the material produces a favourable entrance angle and an unfavourable exit angle. A small distance between the top of the saw plate and the material produces an unfavourable entrance angle and a favourable exit angle.

In practice, the height setting is used to influence the quality of the cutting edge. In general, the ideal quality of the cut is achieved if the entrance angle into the material is the same as the exit angle (45°). A distance of 3 to 4 cm between the top of the saw plate and the material is used as a general guideline for the saw plate's height setting.

SCORING

The optimal cutting quality on the underside of the panel is achieved by first scoring the surface. With this method, the underside of the panel is scored using a small saw plate (scoring saw). The scoring saw is always used parallel to the feed direction, regardless of the direction of use of the next saw plate.

A disadvantage with scoring is that the scoring saw and the actual saw must be accurately aligned. If this is not the case, then the cut is not the same width along the entire length of the cut and the expected quality of the cutting edge is not achieved.

GENERAL GUIDELINES

The recommendations below are given to achieve a good result when using a circular saw. If problems still occur when sawing Trespa panels, refer to section 2.4 for solutions to the most common sawing problems.

- Preferably use HM tools.
 - When machining thicker Trespa panels, use a saw plate with a trapezium flat tooth.
 - If less is demanded of the tool life and the finishing quality, then a flat tooth can be used.
 - A saw plate with a flat tooth is recommended when working with thinner Trespa panels.
 - Set the saw plate to the correct height.
 - Have the visible side facing upwards (see figure 13).
 - Make sure there is a small opening between the saw plate and the worktop.
 - Push the panels firmly against the worktop, particularly close to the saw.
- **Band saw**
Band saws are suitable for sawing panels, particularly when sawing non-straight lines. Thin HM bands with a small tooth-to-tooth distance are recommended to achieve a long tool life and a good finishing quality. Table 2 gives some guidelines for a band saw.

Blade thickness [mm]	0.8 – 1.2
Tooth angle [mm]	4 - 6
Clearance angle	5° - 8°
Cutting speed [m/s]	25 - 33
Feed speed [mm/tooth]	0.02 – 0.05

- **Water jet saw**

Water jet sawing is a relatively new method, which can also be used to saw Trespa panels. A water jet saw is often CNC controlled.

Characteristics of this method are a very high cutting edge quality, a small loss of material and relatively high costs per metre.

2.4 Possible problems when sawing

Problem	Observation	Cause	Solution
Material burns.	<ul style="list-style-type: none"> ■ Smoke and nasty smell when sawing. ■ Green/yellow/brown colour-ation of the core material. 	<ul style="list-style-type: none"> ■ Feed speed is too fast. ■ The wrong guide is used or none is used at all. 	<ul style="list-style-type: none"> ■ Reduce the feed speed. ■ Fit the guide correctly.
The cutting edges splinter.	<ul style="list-style-type: none"> ■ Visual inspection of the edges. 	<ul style="list-style-type: none"> ■ Blunt saw. ■ Saw incorrectly ground. ■ Feed speed is too fast. ■ Incorrect saw plate height setting. 	<ul style="list-style-type: none"> ■ Check and grind the saw. ■ Grind the saw. ■ Reduce the feed speed. ■ Set the saw plate to the correct height.
Low tool life of the saw plate.	<ul style="list-style-type: none"> ■ Registration of the sawing hours. 	<ul style="list-style-type: none"> ■ Saw incorrectly ground. ■ Rotational speed too high. ■ Feed speed too high. ■ Incorrect saw plate height setting. ■ Incorrect tooth shape ■ Incorrect tooth geometry 	<ul style="list-style-type: none"> ■ Grind the saw. ■ Reduce the rotational speed. ■ Reduce the feed speed. ■ Set the saw plate to the correct height. ■ Use a trapezium flat tooth. ■ See table 1 for the preferred values.
Scratches on the décor.	<ul style="list-style-type: none"> ■ Visual inspection of the surface. 	<ul style="list-style-type: none"> ■ Panel slides over a rough surface. 	<ul style="list-style-type: none"> ■ Lay a protective plate under the panel when feeding it into the machine. ■ Use a stationary machine with a moving worktop.

3. Finishing (of edges)

3.1 Introduction

Trespa panels can be finished using both hand tools and fixed machines. The panel can be finished by sanding, planing, routing or polishing. In practice, a number of these methods are used together. Choosing a certain method depends on:

- The required finishing quality.
- The shape.
- The total number of metres to be machined.

Particularly for interior applications, high demands are placed on the finishing of Trespa panels.

After a certain machining method has been chosen, a choice has to be made concerning the tool to be used and its setting. The total number of metres to be machined usually determines this choice. Particularly for larger series, the use of fixed machines where a number of different machining processes are carried out in succession in one fixture is cost-effective.

3.2 Tools

3.2.1 Hand tools

Hand tools are often used with smaller series.

- Files, sandpaper and scrapers

A file is very suitable for finishing edges. Cut files are preferred to milled files. The file should always be used in the direction of the core material. The edges can be finished with a fine file, sandpaper (grain size 100-150) or a scraper.

- Plane

A hand plane can also be used to finish the edges. A metal block plane with a high-speed steel chisel is recommended to achieve good results.

Use a chisel with a cutting angle of approximately 15° and keep the chisel sharp.

- Hand router

A hand router is very suitable for finishing the edges of panels. There are a large number of different shapes; the facet edge is the most common. Each shape requires a different router bit. A hand router can also make recesses in the panel surface. HSS is the recommended tool material.



A number of router bits

A number of guidelines for the setting of a router are given in table 3.

Router diameter [mm]	20-25
Cutting speed [m/s]	20 – 30
Rotational speed [r.p.m.]	18,000 – 24,000
Feed [m/min]	5

The rotational speed of the router can be determined using the guidelines for the cutting speed. The guideline for the feed of the router can be checked by relating the time necessary to feed the material to the length of the material to be machined.

ROTATIONAL SPEED

The rotational speed of the router depends on its diameter and the desired cutting speed. The rotational speed is calculated using the following formula.

$$n = \frac{v \times 60}{\pi \times D}$$

n = Rotational speed of the router	[r.p.m.]
v = Cutting speed	[m/s]
D = Diameter of the router	[m]
$\pi = 3.14$	[-]

Example:

Router \varnothing 25 mm; desired cutting speed 25 m/s. The rotational speed is then:

$$n = \frac{v \times 60}{\pi \times D} = \frac{25 \times 60}{\pi \times 0.025} = 19100 \approx 19000 \text{ r.p.m.}$$

GUIDELINES FOR A HAND ROUTER

Since a hand router is moved over the surface of the panel whilst machining, there is a chance that the surface will be damaged. Damage can be prevented by covering the running surface of the machine with a material that will not scratch the surface, such as laminate. It is also recommended to cover the surface if the running surface has rollers.

Keeping the panel surface free of sawdust and chips during the machining process gives a better view, which produces the optimal result.

- **Polishing discs**

Polishing the edges after they have been finished produces a high quality finish to the edges.

3.2.2 Fixed machines

- **Bench router (multi-purpose machine)**

A bench router is used to finish the edges or to make recesses. HM tools are recommended.



Router head

To achieve a good result when using a bench router, the correct choice has to be made concerning the router head, together with the feed speed and cutting speed.

TRESPA®

The number of teeth, the clearance angle and the cutting-edge side rake characterizes a router head. These characteristics also determine the tool life of the router head. Table 4 gives a number of guidelines for the feed speed and the cutting speed.

Router head diameter [mm]	± 125
Cutting speed [m/s]	40 – 60
Rotational speed [r.p.m.]	6000 – 9000
Feed speed [m/min]	5 - 15

The rotational speed of the bench router can be determined using the guidelines for the cutting speed. The feed speed depends on the bench router's depth setting.

ROTATIONAL SPEED

The rotational speed of the bench router depends on its diameter and the desired cutting speed. The rotational speed is calculated using the following formula.

$$n = \frac{v \times 60}{\pi \times D}$$

n = Rotational speed of the router [r.p.m.]

v = Cutting speed [m/s]

D = Diameter of the bench router [m]

$\pi = 3.14$

Example:

Bench router Ø 125 mm; desired cutting speed 50 m/s. The rotational speed is then:

$$n = \frac{v \times 60}{\pi \times D} = \frac{50 \times 60}{\pi \times 0.125} = 7639 \approx 8000 \text{ r.p.m.}$$

GUIDELINES FOR A BENCH ROUTER

A duplicating router with templates is recommended for the production of large series of panels or for copying letters onto panels.

■ Planing machine

Due to the limited tool life of standard chisels, a planing machine is only of limited use. Table 5 gives a number of guidelines for the use of a planing machine.

Number of chisels	2 – 4
Cutting angle	15°
Cutting speed [m/s]	12 - 15
Feed speed [m/min]	5 - 15

■ Duplicating router

A duplicating router makes it possible to copy certain machining processes and even complete models. The process or the model to be copied is traced using a tracer (either electronic or manual) and then copied.

■ CNC

A CNC controlled machine makes it possible to produce relatively complicated shapes in a reproducible way.

4. Drilling

4.1 Introduction

Drilling is carried out to fix a means of attachment in Trespa panels. It is not possible to fix a means of attachment in a panel without some form of pre-treatment.

The choice of tool to be used and its setting depend on the method and type of attachment.

In practice, drilling is almost always carried out using an electric hand drill. Only the rotational speed can be altered on these tools. A hand drill is a good enough tool to be used, but the quality depends for an even larger part on the person using it.

For larger series, a fixed drilling machine with automatic feed is recommended. Thanks to the automatic feed and the large number of different settings, these machines have a large degree of reproducibility.

4.2 Tools

High-speed steel (HSS) is the recommended tool material for normal applications. This material has a sufficiently long tool life and is easy to grind. HM is recommended for the production of larger series or if a high degree of reproducibility is required.

The different types of drill bits are discussed below. These drill bits are used on hand drills and fixed drilling machines. The way in which they are fixed differs.

■ Spiral drill bits

Spiral drill bits can be used for all kinds of drilling work. Drill bits made from high-speed steel (HSS) with a nose angle of 60°-80° and a large angle of twist are the most suitable. For comparison, a standard steel drill bit has a nose angle of 120° and a small angle of twist. If a standard steel drill bit is used, then the drill should be removed a number of times whilst drilling, so that the chips can be removed from the hole.

■ Double cutting spiral drill bits with a centring point

These drill bits are suitable for drilling dowel holes, plugholes and grooves. They are not suitable for drilling all the way through panels. HSS tools are recommended.

■ Combination drill bits with a centring point

These drill bits are suitable for drilling larger holes, such as for fitting hinges and locks. For larger drill bit diameters, an HM combination drill bit with 3 cutting edges is preferred over a drill bit with 2 cutting edges, because of the longer tool life (reproducibility).



Combination drill bits

■ Tap

Metric screw threads can be tapped using a tommy bar or a drilling machine. The drilling machine must have a special cutting head. The rotational speed and the feed of the drilling machine can be determined using the guidelines for the drilling speed and the feed speed. Table 6 gives a number of guidelines for drilling.

Nose angle	60 - 80°
Angle of twist	???
Drilling speed HSS [m/s]	Approx. 0.8
Drilling speed HM [m/s]	Approx. 1.6
Feed speed [mm/rev.]	0.02 – 0.05

ROTATIONAL SPEED

The rotational speed of the drill depends on the diameter of the drill bit and the desired drilling speed. The rotational speed is calculated using the following formula.

$$n = \frac{v \times 60}{\pi \times D}$$

n = Rotational speed of the drill [r.p.m.]
 v = Drilling speed [m/s]
 D = Drill bit diameter [m]
 π = 3.14

Example:

Drill bit Ø 6 mm; desired drilling speed 0.8 m/s. The rotational speed is then:

$$n = \frac{v \times 60}{\pi \times D} = \frac{0,8 \times 60}{\pi \times 0,006} = 2546 \approx 2500 \text{ r.p.m.}$$

FEED

The feed of the drill depends on the rotational speed of the drill. The feed is calculated using the following formula:

S = Sz x n
 S = Drill feed [mm/min.]
 Sz = Feed per revolution [mm/rev.]
 n = Rotational speed of the drill [r.p.m.]

Example:

Drill bit Ø 6 (HSS), desired drill feed: 0.02 mm/rev. The feed is then:

$$S = Sz \times n = 0.02 \times 2500 = 50 \text{ mm/min}$$

In practice, the drilling is almost always carried out using an electric hand drill, so that only the rotational speed is variable. The calculation of the feed is then only a guideline.

4.3 General guidelines

A number of recommendations are given below to achieve a good result when drilling. If problems still occur when drilling Trespa panels, please refer to the page containing solutions to the most common drilling problems.

The recommendations are divided into drilling techniques and the hole geometry. The second category is included so that the correct hole diameter and hole depth are always achieved.

DRILLING TECHNIQUES

- Overheating and damage to the panel are prevented using a drill feed speed of 0.02-0.05 mm per revolution.
- If a standard steel drill bit is used, then the drill should be removed a number of times whilst drilling so that the chips can be removed from the hole.
- When drilling right through the panel, place a hardwood panel under the Trespa panel to prevent the material from splintering when the drill exits the material.
- For mass production, a better result is achieved using drilling templates that have drilling bushes on both sides.

- When countersinking holes, the rotational speed (r.p.m.) should be reduced by half.

HOLE GEOMETRY

Visible attachment:

- When using a screw or bolt connection that goes all the way through the panel, sufficient play must be maintained on all sides. The recommended hole size is at least 1.5-2.0 times the screw or bolt diameter.

Blind attachments (panel thickness ≥ 8 mm):

- Holes for parkers, etc. in the surface of the panel must be pre-drilled approximately 0.3-0.5 mm smaller than the diameter of the screw.
- Holes for parkers, etc. in the cross cut end of the panel must be pre-drilled approximately 0.5-0.7 mm smaller than the diameter of the screw.
- Holes for screws that do not go all the way through the panel should be drilled at least 1 mm deeper than the maximum penetration depth of the screw.
- There should be a minimum panel thickness remaining for holes that do not do all the way through the panel (see figure 16).
 - Interior use: Minimum $a = 1.5$ mm
 - Exterior use: Minimum $a = 3.0$ mm
- When drilling parallel to the surface of the panel, there should be a minimum thickness of panel remaining: $b = 3.0$ mm.

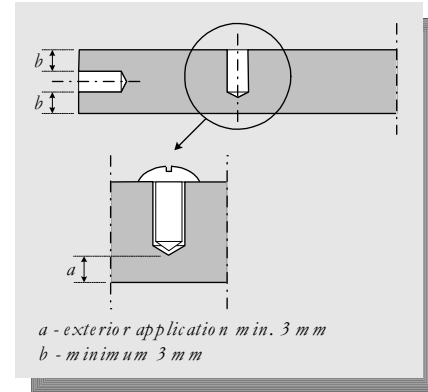

4.4 Possible problems when drilling

Problem	Observation	Cause	Solution
Burning of the material.	<ul style="list-style-type: none"> Production of smoke and nasty smell whilst drilling. Brown coloration of the core material. 	<ul style="list-style-type: none"> Too high feed speed. Blunt drill. Wrong type of drill. 	<ul style="list-style-type: none"> Reduce the feed speed. Grind the drill. Use a drill with the correct nose angle and a larger angle of twist.
Splintering when the drill exits the material.	<ul style="list-style-type: none"> Visual inspection. 	<ul style="list-style-type: none"> Blunt drill. Too high feed. Panel is poorly supported. 	<ul style="list-style-type: none"> Check and grind the drill. Reduce the feed. Use a (hardwood) protective plate.
Low drill tool life.	<ul style="list-style-type: none"> Registration of the drilling hours. 	<ul style="list-style-type: none"> Incorrectly ground drill. Too high rotational speed. Too high feed. Wrong type of drill. Wrong tool material. 	<ul style="list-style-type: none"> Grind the drill. Reduce the rotational speed. Reduce the feed. Use a drill with the correct nose angle and a larger angle of twist. Use HM instead of HSS.
Scratches on the décor.	<ul style="list-style-type: none"> Visual inspection of the panel surface. 	<ul style="list-style-type: none"> The panel slides over a rough surface. 	<ul style="list-style-type: none"> Use a protective plate when feeding the panel into the machine. Use a stationary machine with a moveable feed table.



5. Punching

6. Suppliers

Trespa has a long-standing partnership with Leuco.

Registered trademarks

® Trespa, Meteon, Athlon, TopLab, Virtuon, Volkern, Ioniq and Inspirations are registered trademarks of Trespa International B.V.

Responsibility

All information in this document is based on our current state of knowledge. It is intended as information concerning our products and their application possibilities, and is therefore not intended as any form of guarantee with regard to any specific product characteristic.

Copyrights

© All rights reserved. No part of this publication may be reproduced, stored in a retrieval system or made public, in any form or by any means, either graphic, electronic or mechanical, including photocopying, recording or otherwise, without the prior written permission of Trespa International B.V.